

Ease of build	Easy
-partscount	Low
-density	Medium
Parts sourcing	Advanced
Enclosure fitting	Easy
Debugging level	Easy

# 5-band graphic EQ METAL Version V1.3b

## OVERVIEW

This circuit features a special application chip to allow a slimline 5-Band EQ with +/-12dB in each band.

## GENERAL

The chip does allow you to calc your own cap values to really build an equalizer with the frequency bands where you need them.

You also can chain multiple of those boards to set up more than the initial five frequency bands.

Using the below formulas will allow you to define Q and frequency of each frequency band:

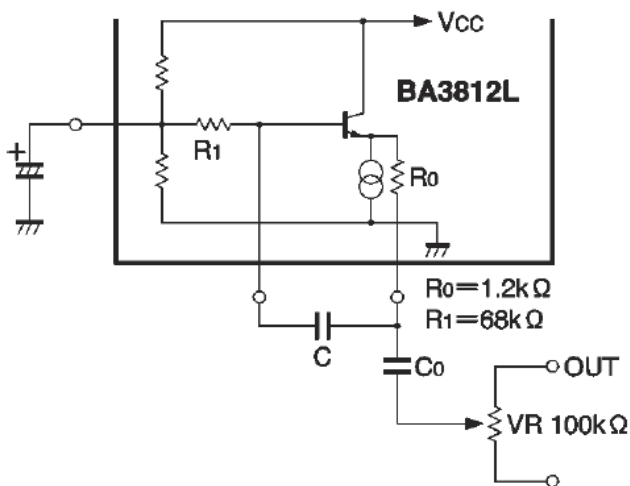

$$Q = \sqrt{\frac{CR_1}{C_0 R_0}}$$

$$f_0 \text{ (Hz)} = \frac{1}{2\pi\sqrt{R_0 R_1 C C_0}} \quad (\text{R: } \Omega, \text{ C: F})$$

Common values:

	100Hz	300Hz	1kHz	3kHz	10kHz
C0	1u	330n	100n	33n	10n
C	27n	8n2	2n7	820p	270p

METAL Values:

	81Hz	170Hz	455Hz	1440kHz	4500Hz
C0	1u	470n	220n	68n	22n
C	47n	22n	6n8	2n2	680p

Please note that the frequency bands in the schematic are not in any order. So if you want F1 to be 100Hz you need to use 1uF for C13 and 27n for C12.

SCHEMATIC

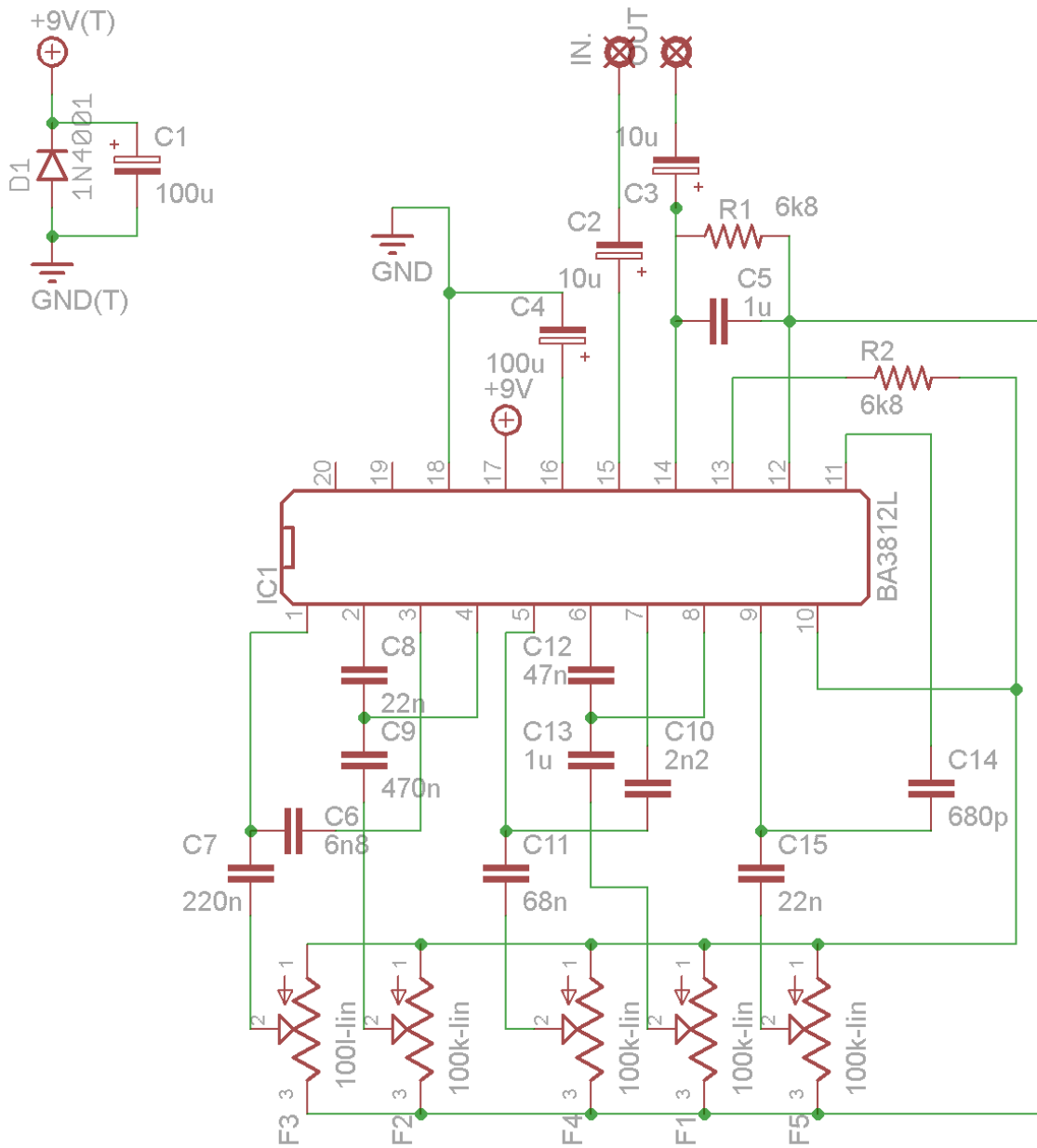

## BILL OF MATERIALS

	Device#	Qty	Value	Comment
<b>Resistors</b>	R1, R2	2	6k8	
<b>Capacitors</b>	C1,C4	2	100u	polarized electro
	C2,C3	2	10u	polarized electro
	C5	1	1n	box cap
<b>F1</b>	C13,C12		1u/47n	81Hz
<b>F2</b>	C9,C8		470n/22n	170Hz
<b>F3</b>	C7,C6		220n/6n8	455Hz
<b>F4</b>	C11,C10		68n/2n2	1440Hz
<b>F5</b>	C15,C14		22n/670p	4500Hz
<b>Pots</b>	F1-F5	5	100k-lin	9mm Alpha
<b>Diodes</b>	D1	1	1n4001	
<b>ICs</b>	IC1	1	BA3812L	

## BUILDING

Start populating resistors and diode first, then the IC and capacitors. Use low profile electrolytic caps to reduce build height. C5 is 1nF only. Board and prototype had 1uF but worked fine as well. Please note that Pin 1 of the long IC is at the left hand side.

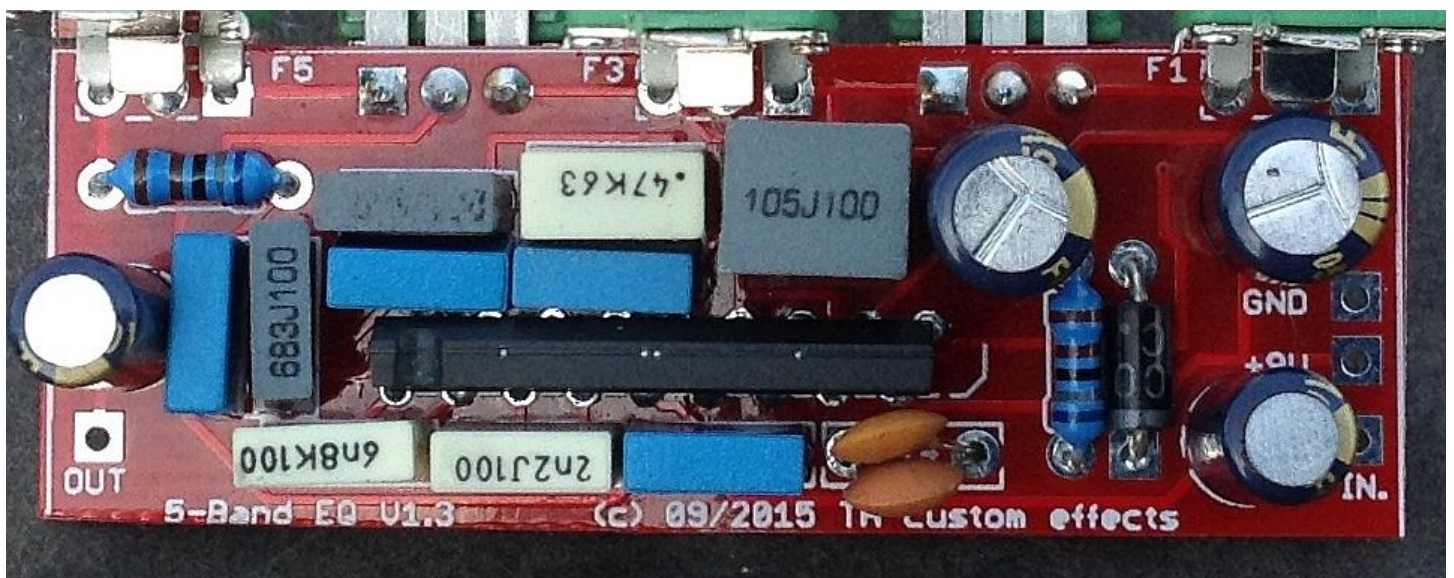
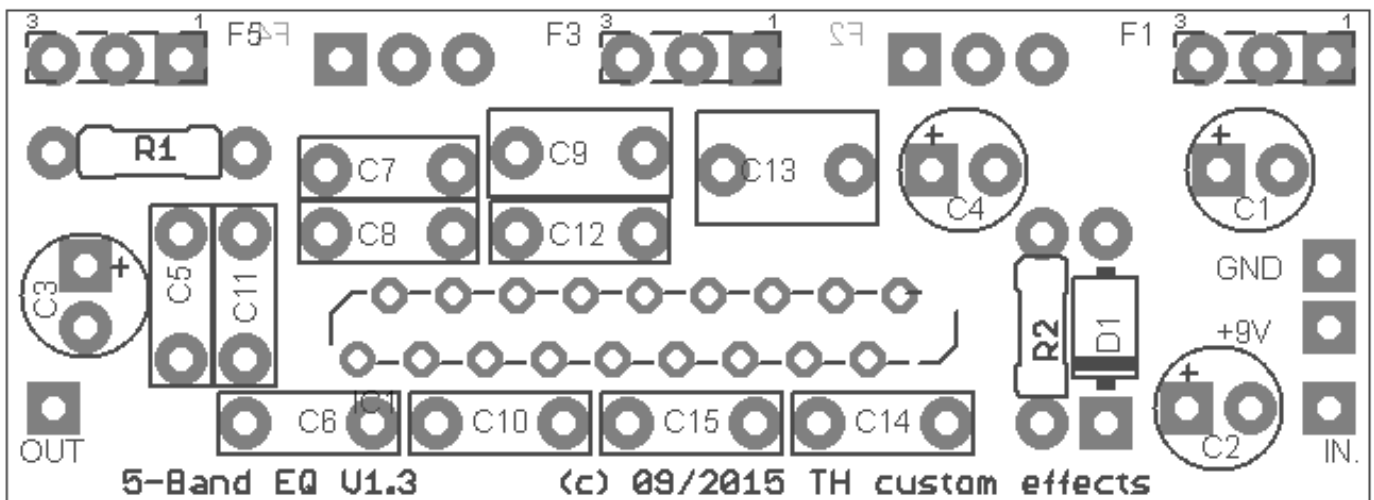

## TIP

If you use this together with another effect in the same enclosure you might not need the decoupling caps C2,C3. Jumper them if you are sure you don't need them.

## FINALLY

You now have made a very universal circuit which can be used in many ways and applications.

This picture shows how it fits in a 1590B enclosure:

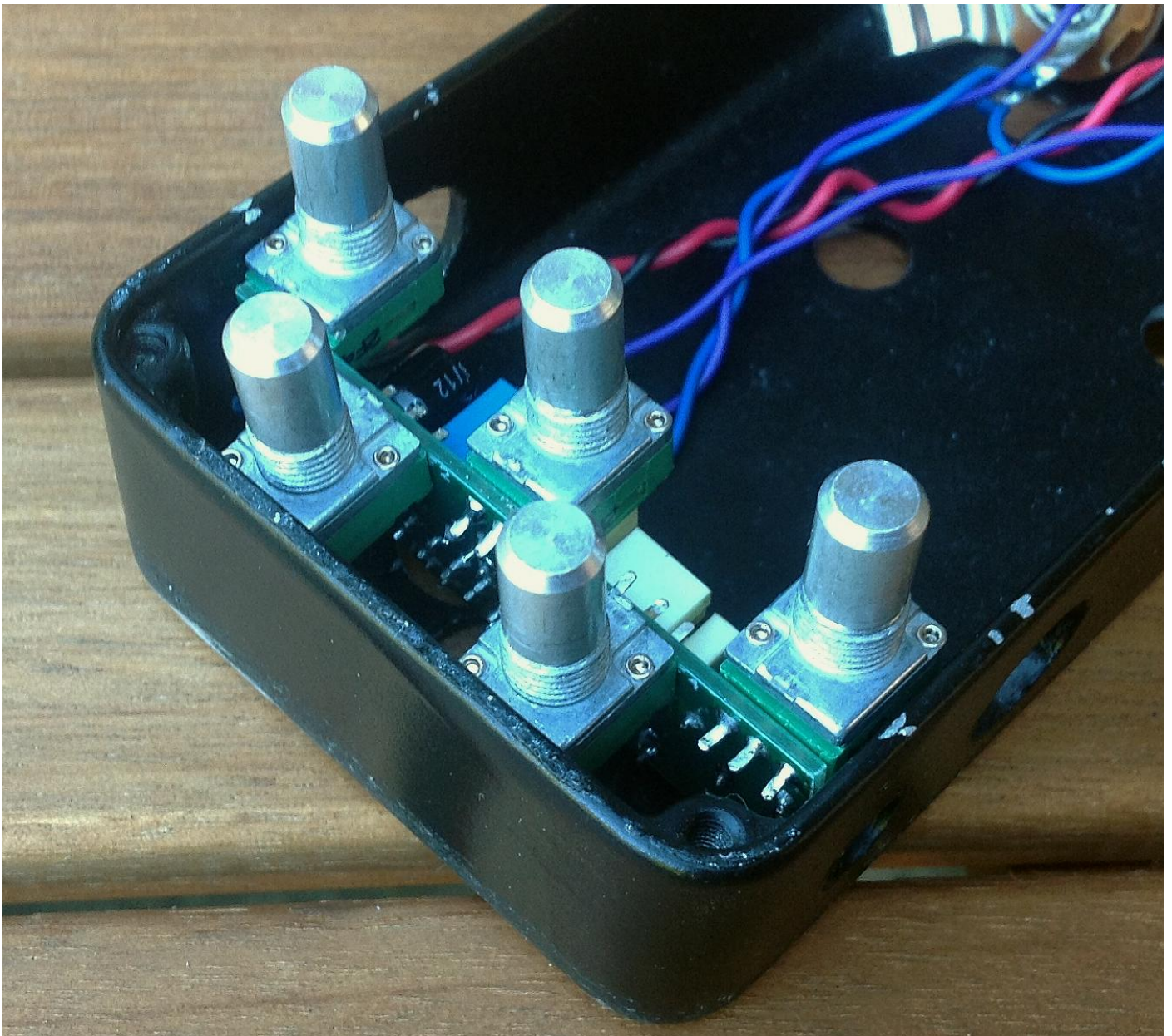

## DISCLAIMER & LICENSE

PCBs purchased from TH custom effects are intended for DIY / non-commercial use only. It is not allowed to redistribute the PCBs and artwork from this document. However, you can use these instructions and PCBs to build and sell your own product based on PCBs ordered from TH custom effects.